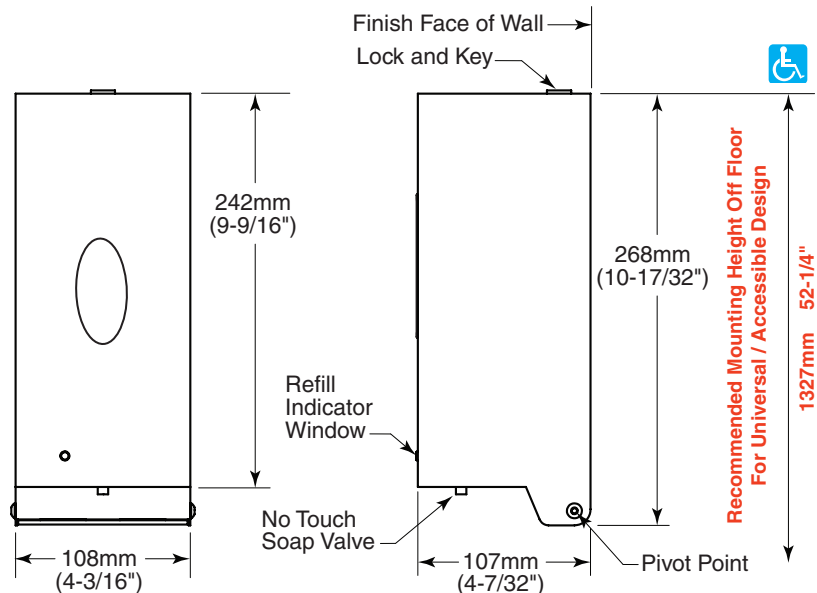

**BOBRICK****Technical Data****AUTOMATIC  
WALL-MOUNTED  
SOAP DISPENSER****B-2012****MATERIALS:**

**Housing** — Welded 18-8, Type-304, 18-gauge (1.0 mm) stainless steel with satin-finish. Plastic back plate incorporates mounting screw holes and mounting tape. Equipped with concealed mounting, clear acrylic refill-indicator window and key lock. Refillable, plastic container. Capacity: 850 ml (30-fl oz).

**Valve** — No-touch, sensor-activated valve suitable for liquid soap, alcohol gel, liquid alcohol, hand sanitizers and iodine.

**Spare Part** — Replace 2012-18-S silicone tube pump every three to six months, depending on usage, if using the dispenser with alcohol-based solutions.

**OPERATION:**

To fill the dispenser, remove the lid and fill with liquid hand soap. Dispenses liquid hand soaps of viscosities ranging from 1-3,000 cps. After filling soap container, DO NOT TIGHTEN lid. Air flow is necessary inside the container for dispensing. To activate the dispenser, place hand under spout for approximately one second. Sensing range comes at factory setting of 60mm (2-1/2"). The sensing range set by the factory is recommended for optimal performance. Window indicates when refill is required. The locked, hinged housing opens for re-filling only with special key provided. Requires three (3) Alkaline "C" Cell Batteries, 1.5V (not included). Blue indicator light signals "IN USE". Flashing blue light signals "LOW BATTERY." CE Certified.

**INSTALLATION:**

Install dispenser at least 200 mm (8") from any projection or horizontal surface which may interfere with the operation of the automatic sensor. Mount the dispenser to the wall by using the enclosed screws and wall plugs. The prepared mounting tape may also be used. Make sure the wall surface is cleaned and in good condition to ensure proper mating of the dispenser to the wall. Install three (3) Alkaline "C" Cell Batteries, 1.5V and replace battery cover. After filling soap container, DO NOT TIGHTEN lid. Air flow is necessary inside the container for dispensing. Remove and discard plastic cap from nozzle tip. Plastic dispensing tube may require massaging to prime the unit. Housing must be closed for dispenser to function.

**SPECIFICATION:**

Automatic wall-mounted soap dispenser shall be Type-304 stainless steel with satin-finish. Corrosion-resistant valve shall dispense a variety of liquid soaps, iodine based soaps, and alcohol based liquid or gel hand sanitizers. Valve shall be sensor-activated and not require contact with the dispenser to function. Lockable housing shall be equipped with a clear acrylic refill-indicator window and be hinged for refilling and maintenance. Container shall have a capacity of 850 ml (30-fl oz). Unit shall have CE Certification.

**Surface-Mounted Sensor-Operated Soap Dispenser shall be Model B-2012 of Bobrick Washroom Equipment, Inc., Clifton Park, New York; Jackson, Tennessee; Los Angeles, California; Bobrick Washroom Equipment Company, Scarborough, Ontario; Bobrick Washroom Equipment Pty. Ltd., Australia; and Bobrick Washroom Equipment Limited, United Kingdom.**